

# Stepping-motor Analogue Indicator NORIMETER 3 Round Variant



- Microprocessor-controlled robust indicator with long service life
- Exact indication due to high accuracy class rating of < 0.5
- Direct connection of all usual measuring signals, inputs galvanically isolated
- Low power consumption (<2 W) for 18 V to 36 V operation, therefore very little self-heating
- Robust fibreglass reinforced plastic housing
- Operation possible in any installed position
- Front-plate protection against spray water, flooding and temporary submersion (on request, also for the connection area)
- Vibration resistant up to 4 g, shock resistant up to 10 g
- Bright, uniform LED scales and optional pointer illumination due to innovative lighting design
- Illumination brightness can be regulated externally in 100 increments
- Additional setting for standard brightness allows adaptation to adjacent instruments
- Control function for sensor and auxiliary power outage (live zero)
- Pointer always returns to zero or live zero position after switch-off
- No transverse acceleration on curves, no overshooting as in the case of moving-coil indicators
- Up to 300° pointer scale angle; 360° plus path optimisation with full-circle indicator disc
- Options include non-linear scale division, scale spreading and arbitrary zero position
- Adaptable to customer needs, many special functions and additional features possible
- Meets all conventional ship classifications and railway standards



Analogue Indicator NIR3...



Germanischer Lloyd

## Stepping-motor Analogue Indicator NIR3...

### Equipment Features

The NORIMETER 3 standard indicator is a third-generation analogue indicator. Its movement is operated by a microprocessor-controlled stepping-motor. It is a completely new development employing the latest technology. As a consequence of its stable fibreglass reinforced plastic housing, its thought-through design and robust electronics, it is an instrument deliberately built for long service life and trouble free operation. Its front-side face, made of lumenized float glass, makes the instrument essentially insensitive to scratching. In its installed state, the instrument's front side meets the requirements for housing protection classes IP66 and IP67.

The instrument's only moving part is a high-resolution stepping-motor with integrated reduction gearbox and a robustly mounted shaft. This makes the pointer insensitive to vibration, even in continuous operation. The motor's operation is controlled by digitally filtered software that optimally combines smooth tracking of the measured value with high precision – but without wavering pointer motion.

All types of compensation potentiometers were deliberately avoided in the electronics because of their susceptibility to malfunctions. There are only two rear-side pushbuttons on the instrument; these are for setting standard brightness and other parameters. Particular attention was given to a bright, uniformly-illuminated scale. This is especially impressive with white scales.

In order to provide a fitting solution for many applications, these instruments have been designed in many shapes and variations. Thus the fabrication of custom scales with appropriate logos is not a problem. Even certain optional features, such as an additional status LED or an integrated limit value switch, etc., can be realised.

### Indicator Accuracy - Standard (240°) and 300° Instruments

All NORIMETER 3 standard instruments are driven by a stepping-motor with integrated reduction gearbox which yields a resolution of 12 steps per degree. This achieves indicator accuracy of better than 0.5 % of the measured range.

Instruments with a pointer use a 315° motor with a mechanical limit which permits a maximum scale angle of 300° (standard = 240°). An instrument with a 240° scale thus resolves the measurement signal into 2880 display steps. Every time the instrument is switched on, its motor will first make a reference travel cycle to the mechanical limit in order to renew calibration of its mechanical zero point.

### Indicator Accuracy - 360° Instruments

The 360° instruments use a motor without mechanical limit, thus permitting continuous rotation of the pointer disc. These instruments can have 360° scales, such as those needed to display rudder propeller drive angle, for display of wind direction, or as compass indicators, etc. On a 360° scale the entire measurement range is divided into 4300 display steps. Since the motor in this instrument has no mechanical limit, the zero point reference is accomplished by laser sensing positioning marks on the underside of the indicator disc. This is why such a 360° instrument cannot be delivered with a pointer.

The stepping-motor's gearbox backlash is eliminated by way of special motor control. This approach makes almost point-precise positioning of the indicator disc possible in either direction. Furthermore, the instrument performs a gearbox backlash correction every second when the display is at a standstill. Thus if an impact or vibration should cause deviation from the correct value due to gearbox backlash, it will be corrected very quickly.

**Calibration, Spread or Non-Linear Measurement Range, Zero Position**

The instrument's factory calibration can be performed with up to 12 freely selectable calibration points along the scale. The indicator will behave linearly between calibration points. This method permits an unlimited number of scale spreads to be realised so that pseudo non-linear measurement ranges can be created. Furthermore, this technique permits the indicator's zero point to be put in the middle or at any other point along the scale. In the event of a power outage, the indicator always returns to this zero position or to another position specified by the customer.

**Scale**

The scale is fabricated individually to customer specification. Scale markings and divisions are made in compliance with DIN 43802 and DIN 43780. Customer specified colour and form deviations from these standards will be accommodated.

White scales are produced in a special printing process with thermally hardened inks. This process results in very short lead times. Black scales must be highly opaque because of the bright scale illumination. As a consequence, these are made in a screen printing process. Both printing processes guarantee very good light stability for the scale.

Scale and pointer: Standard variants	
Scale lettering and subdivision to DIN 43802 and DIN 43780	
Illuminated white scale	Scale lettering: black Pointer: black non-illuminated
Illuminated black scale	Scale lettering: white Luminous pointer: white, when lighted red

Scale and pointer: Individual variations	
Illuminated scale	Through-lighted scale black or white, when lighted red, green or yellow
Lettering	In any customer specified colour, customer logos possible
Markings	Divisions, ranges or scale arc in any colour
Scale division	Pilot scale divisions, coarse or fine division individually to customer request possible
Pointer variants	Pointer: non-illuminated black Luminous pointer: non-illuminated white; when lighted red, green or yellow Luminous pointer: non-illuminated yellow; when lighted yellow Luminous pointer: non-illuminated red; when lighted red Indicator disc illuminated white for 360° indicator

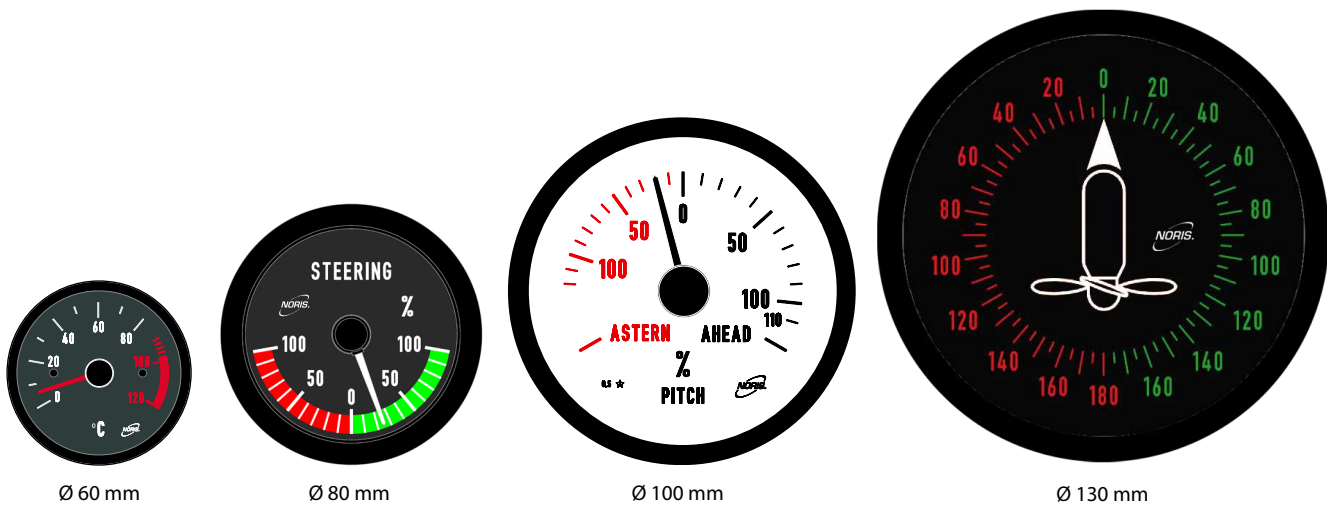

**Illumination**

Standard NORIMETER 3 indicators have LED scale illumination which can be regulated. This backlight illumination through the scale is uniform and bright. This uniform illumination is achieved by a surface light conductor imprinted with a computer-calculated grid of reflection points covered by a diffusion plate. Brightness of the LEDs is set internally by way of pulse width modulation (PWM) to keep the indicator's consumed power and self-heating low.

The indicator's connector has an input pin for external illumination regulation which allows brightness to be set from 0 % to 100 % in a maximum of 100 increments. This regulation input is optimised for conventional 24V dimmers with PWM technology. However, brightness can also be controlled with variable DC voltage from 0 ... 24 V of either polarity which, for example, could be set with a potentiometer connected to the regulator input.

For those models with a light pointer, extra pointer illumination in various colours is possible. This is especially advantageous for black scales. Together with scale illumination, pointer illumination is also regulated in 100 increments.

Standard brightness can be set between 30 % and 100 % of maximum brightness with the two pushbuttons on the rear of the housing. This allows the instrument's illumination to be adapted to other components, e. g. in a switchgear cabinet.

**Measurement Signal Monitoring, Fault Detection - Standard (240°) and 300° Instruments**

Integrated measurement signal monitoring continuously tests the measurement signal for validity within a measurement range. On instruments with "live zero", this permits detection of sensor outages, line breaks and short circuited sensor leads.

On instruments with a pointer, the pointer will move outside the valid scale range and the instrument's illumination (scale and pointer) will blink slowly at maximum brightness to clearly signal the faulty sensor signal.

**Measurement Signal Monitoring, Fault Detection - 360° Instruments**

On 360° instruments, illumination will also blink as described above. However, the indicator will remain in the valid range because, for a 360° scale, there is no invalid range.

Instruments with 360° indicators additionally monitor the laser sensing of the positioning marks. To prevent the instrument from indicating a false value, a "fault" will trigger a permanent fault indication. During this fault indication state, illumination will blink rapidly at maximum brightness and the indicator will change alternately between two points 180° apart on the scale, regardless of the measurement signal's value.

## Special Functions

Optionally, NORIMETER 3 standard instruments can be equipped with the following described special functions. If functions are desired which are not described here, they can, if possible, be developed in conjunction with our development department.

### Line Compensation (Voltage Input 0 ... 10 V / 2 ... 10 V)

When needed, line compensation can be performed by way of the two pushbuttons on the rear side of these instruments. This can change the indication by as much as  $\pm 10\%$  of displayed value.

### Min/Max Display

These instruments record measurement signal fluctuations and retain the given highest and lowest measured values in an internal memory. Critical measurement values that, for example, occur during the absence of monitoring personnel, can therefore be recalled later on. These stored values can be brought up on the indicator by connecting an external pushbutton.

### Limit Value Switch Output

The "Auxiliary" connection is designed as a relay output on these instruments. This feature can be used to switch an external device (e. g. a signal beeper or signalling device, etc.) when a certain instrument value has been reached or, alternatively, lies within a certain instrument value range. The output is intended for connection to a common mechanical miniature relay or, optionally, to a current-limited semiconductor relay.

### Signal or Alarm LED

The instrument can optionally be equipped with an additional LED on the scale. This LED can assume the states "off", "on" or "blinking" for use in the following manner:

By coupling it to certain measurement values, e. g. excess speed or over temperature, etc. By correlating it to measurement ranges, e. g. blink within the red measurement range, or illuminate when outside the green measurement range or similar. By control from an external signal on the instrument's "Auxiliary" connection or, if desired, by a combination of an external signal and the measured value together. Another possibility is to have the instrument take notice of a onetime reached "warning range" and have the signal LED indicate that the condition occurred, even though it has since gone away. Only a deliberate reset signal applied to the auxiliary input (24 V connected via a pushbutton switch) will then shut off the LED.

### Blinking Pointer

All of the aforementioned options described for a signal/alarm LED can also be used for an illuminated pointer. The illuminated pointer starts to blink when a signal condition is present. Signal LED and pointer blinking can also be freely used in combination.

### Motor with Clockwise Limit

On request, the instrument can be delivered as a counter clockwise rotating instrument with clockwise limit.

## Types and Connection Diagrams

Here just a selection of the most commonly used signals. Further are available on request.

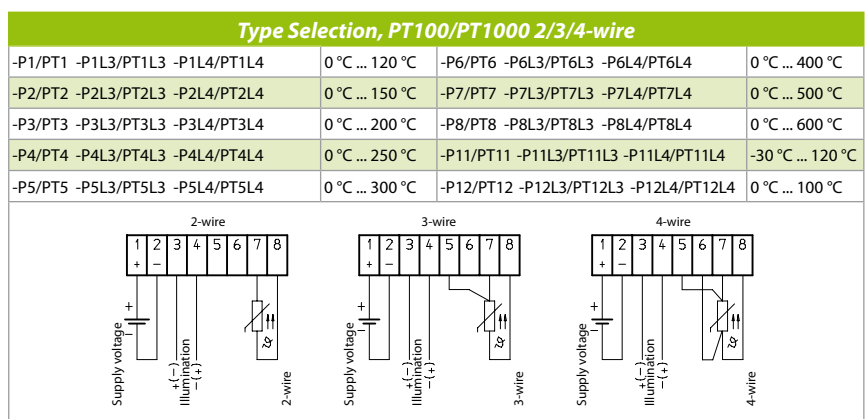
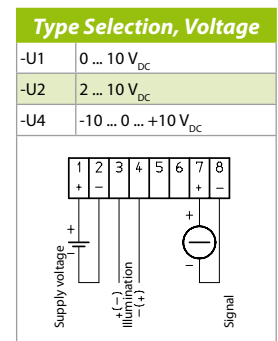
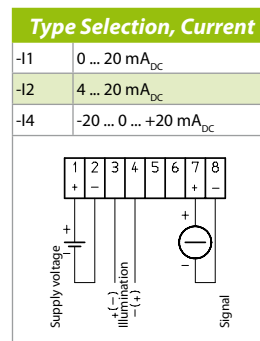
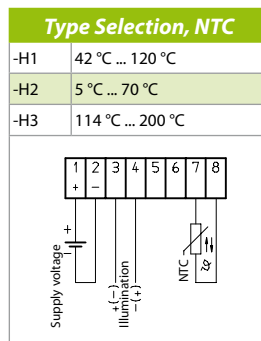
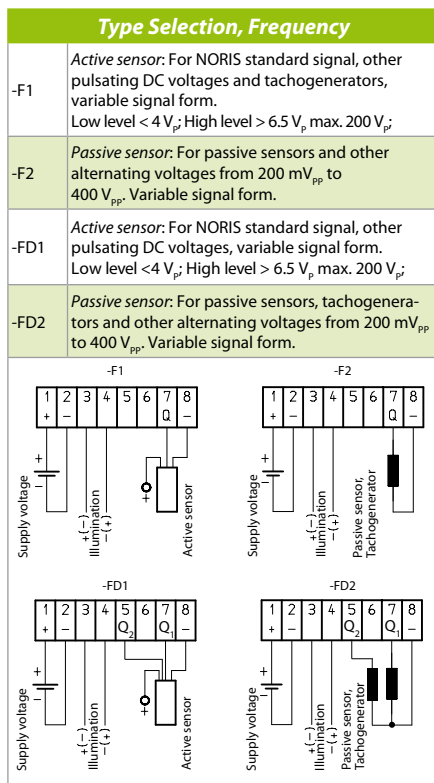

## Electrical Connections

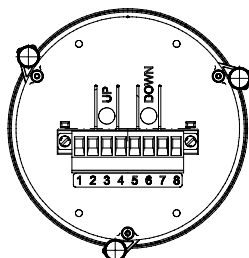

Standard NORIMETER 3 indicators have an 8-pole connector with 4 connection options that are completely galvanically isolated from one another:

Supply voltage (+Pin1, -Pin2)

Regulation input for indicator illumination (Pin3, Pin4), arbitrary polarity

Auxiliary connection (+Pin5, -Pin6)

Analogue measurement input (+Pin7, -Pin8)

# Technical Data

Series NIR3...	
<b>Electrical connections</b>	<b>Supply voltage</b> 18 ... 36 V <sub>DC</sub> at 2 W maximum power consumption; other voltages on request <b>Reverse voltage protection</b> Integrated <b>Over voltage protection</b> Integrated <b>Analogue measuring signals</b> 0 ... 10 V <sub>DC</sub> ; 2 ... 10 V <sub>DC</sub> (R <sub>i</sub> =29 kΩ); 0 ... 20 mA <sub>DC</sub> ; 4 ... 20 mA <sub>DC</sub> (R <sub>i</sub> =121 Ω) -10 V <sub>DC</sub> ... +10 V <sub>DC</sub> (R <sub>i</sub> =26 kΩ); -20 mA <sub>DC</sub> ... +20 mA <sub>DC</sub> (R <sub>i</sub> =59 Ω) <b>Frequency signal</b> Frequency range: 0.2 Hz ... 140 kHz; scale end value from ≥10 Hz arbitrary; Signal form: all signal forms; AC voltage: 200 mV <sub>pp</sub> ... 400 V <sub>pp</sub> ; Pulsating DC voltage: Low level ≤ 4 V; High level ≥ 6.5 V, max. 200 V <sub>p</sub> ; Internal resistance R <sub>i</sub> : >220 kΩ for all signals, 10 kΩ termination possible Possible sensor types: <i>Active sensors</i> with "open collector" as NPN or PNP output or with push-pull output stage <i>Passive sensors</i> : inductive-magnetic principle; <i>Tachogenerators</i> : with AC voltage output <b>Resistive sensor signals</b> PT100/PT1000 in 2-, 3- and 4-wire-technology; -30 °C ... 600 °C; I <sub>MESS</sub> =1.6 mA/0.17 mA NTC-thermistor; H1: 40 °C ... 120 °C; H2: 5 °C ... 70 °C; H3: 114 °C ... 200 °C <b>Illumination regulation input</b> For conventional 24 V PWM dimmer (positive or negative regulator) or 0 ... 24 V DC (this input is insensitive to polarity); R <sub>i</sub> =17 kΩ <b>Auxiliary connection</b> Binary connection. Selectable as input or output as desired. <i>Input</i> : binary switching input; low=0 V; high=12 V/24 V or input for direction of rotation signal at frequency indicator with rotation direction indicator or analogue input for PT100/PT1000 3- or 4-wire connecting techniques <i>Output</i> : switching contact as limit value switch, 2 modes selectable for current-limited semiconductor relay I <sub>max</sub> =100 mA; U <sub>max</sub> =60 V <sub>DC</sub> for magnetic relay I <sub>max</sub> =500 mA; U <sub>max</sub> =60 V <sub>DC</sub>
<b>Accuracy</b>	<b>Accuracy class</b> EN60051 and IEC51-1: better than 0.5 % with respect to measurement span <b>Resolution of measuring signal</b> 10 Bit <b>Resolution stepping-motor</b> Twelve motor steps per angle degree <b>Gear backlash</b> Typically 0.3 angle degrees; gear backlash correction via software
<b>Environmental influences</b>	<b>Operating temperature</b> IEC60068-2-1/2: -25 °C ... +70 °C <b>Climatic test</b> IEC60068-2-30 <b>Storage temperature</b> -40 °C ... +70 °C <b>Vibration resistance</b> IEC60068-2-6: up to 4 g <b>Shock resistance</b> DIN EN 61373: 5 g at 30 ms; 10 g at 18 ms <b>Degree of protection</b> DIN EN 60529: housing front IP66 / IP67 (rear side on request) rear side of housing IP30 (standard) <b>ESD</b> IEC61000-4-2 and EN50121-3-2, table 9.3, evaluation criteria "A": 8 kV for air discharge; 6 kV for contact discharge <b>HF-interference immunity</b> IEC61000-4-3, GL2003 and EN50121-3-2, table 9.1 and 9.2: f=80 MHz ... 1 GHz at 80 % AM @ 1 kHz, E=20 V <sub>eff</sub> /m; f=1,0 GHz ... 2,1 GHz at 80 % AM @ 1 kHz, E=10 V <sub>eff</sub> /m; f=2,1 GHz ... 2,5 GHz at 80 % AM @ 1 kHz, E= 5 V <sub>eff</sub> /m; <b>Burst</b> IEC61000-4-4, GL2003 and EN50121-3-2, table 7.2: 2 kV/PL IEC61000-4-4, EN50121-3-2, table 8.1: 2 kV/DL <b>Surge</b> IEC61000-4-5, GL2003 and EN50121-3-2, table 7.3, evaluation criteria "A": 1.0 kV at the supply voltage with R <sub>i</sub> =2 Ω <b>Conducted HF-interference</b> IEC61000-4-6, GL2003 and EN50121-3-2, table 7.1 and 8.1: f=150 kHz ... 80 MHz at 80 % AM @ 1 kHz, U=10 V <sub>eff</sub> <b>Conducted LF-interference</b> IEC61000-4-6 and GL2003: f=50 Hz ... 10 kHz, U=3 V <sub>eff</sub> <b>Interference emission</b> Housing CISPR16-1/2, EMC1: f=150 kHz ... 2 GHz, s=3 m horizontal and vertical Housing EN50121-3-2 table 6: f=30 MHz ... 1 GHz, s=10 m horizontal and vertical Battery related connections CISPR16-1/2, GL2003 EMC1: f=10 kHz ... 30 MHz Battery related connections EN50121-3-2, table 4: f=150 kHz ... 30 MHz <b>Insulation voltage</b> 1000 V <sub>DC</sub> among all electrical connections
<b>Mechanical quantities</b>	<b>Case material</b> Fibreglass reinforced, UV stabilised plastic; upper part: PC GF10; base plate: PC GF30; face made of lumenized float glass <b>Mounting</b> Fastening screws with dovetail key and hand knob (tool-less) <b>Installation position</b> Any <b>Motor torque</b> Static: 4 mNm; dynamic: 1.2 mNm; <b>Weight</b> Ø 60 mm: 145 g; Ø 80 mm: 185 g; Ø 100 mm: 245 g; Ø 130 mm: 375 g
<b>Other</b>	<b>Illumination</b> External LED illumination regulation; PWM frequency=70 Hz <b>Initialising time</b> Approx. 5 seconds from application of supply voltage <b>Minimum switch on period</b> 2 min., to permanently store a change to standard brightness; 3 min., to return the pointer from any position to its zero point <b>Scale angle</b> With pointer, any up to a maximum of 300° (standard 240°) or 360° with indicator disc <b>Operation</b> Two rear-side pushbuttons for setting various parameters
<b>Approvals</b>	<b>Approvals</b> CE; ABS, BV, DNV, GL, LR, MED (if requested, please explicitly specify when placing the order) <b>Applied standards</b> DIN EN 50121-3-1, DIN EN 50121-3-2, DIN EN 50155, DIN EN 61373, DIN EN 61010-1 <b>Fire protection class</b> V0

# Dimensions

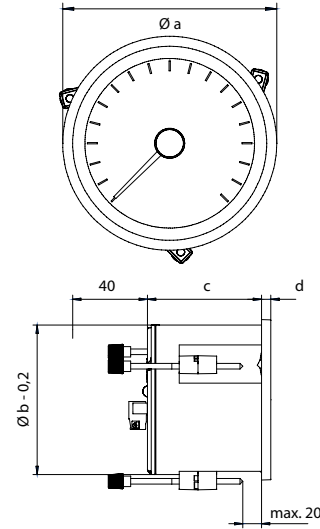

e = console cutout to DIN 43700

Type	a	b	c	d	e
NIR3-060	66	60	61	5	61 <sup>+0,5</sup>
NIR3-080	86	80	61	5	81 <sup>+0,5</sup>
NIR3-100	106	100	61	5	101 <sup>+0,5</sup>
NIR3-130	136	130	63	6	131 <sup>+0,5</sup>

## Type Code for Standard Variants

NIR3	-	060	-	U1	(-)	(e.g. NIR3-060-U1-MED)
1	2	3	*	5	* Pos. 4 not applicable for series NIR3	

1	Device and series
(Standard variants, other available on customer request)	
NIR3	NORIMETER 3 standard stepping-motor indicator, 240° indicator and 300° indicator; round variant, plastic housing, connecting plug Phoenix/MSTB 2,5/8-GF
NIR31	NORIMETER 3 stepping-motor indicator, 360° indicator; round variant, plastic housing, connecting plug Phoenix/MSTB 2,5/8-GF

2	Size	3	Input signal
060	Ø 60 mm	F1	Frequency NORIS Standard
080	Ø 80 mm	F2	Frequency AC voltage
100	Ø 100 mm	FD1	Frequency NORIS Standard with direction of rotation signal
130	Ø 130 mm	FD2	Frequency AC voltage with direction of rotation signal
5	MED approval	H1	NTC-thermistor 42 °C ... 120 °C
		H2	NTC-thermistor 5 °C ... 70 °C
		H3	NTC-thermistor 114 °C ... 200 °C
without	without code means: no MED approval	I1	Current 0 ... 20 mA
MED	MED approval with device marking	I2	Current 4 ... 20 mA
		I4	Current -20 ... 0 ... +20 mA
		I0	Special calibration current
		Px	PT100 -30 °C ... 600 °C
		PTx	PT1000 -30 °C ... 600 °C
		PxL3	PT100 -30 °C ... 600 °C
		PTxL3	PT1000 -30 °C ... 600 °C
		PxL4	PT100 -30 °C ... 600 °C
		PTxL4	PT1000 -30 °C ... 600 °C
		U1	Voltage 0 ... 10 V
		U2	Voltage 2 ... 10 V
		U4	Voltage -10 ... 0 ... +10 V
		U0	Special calibration voltage
		UG0	Special calibration GE1214

## Type Code for Special Variants

NIR3	-	060	V101	(e.g. NIR3-060V101)
1	2	3		

3	Special variants
Vxxx	sequential number (customized)

**MED:** If a MED approval, together with the marking of device, is requested, please explicitly specify when placing the order. The type designation is then marked with "MED".

